



**SRBSYSTEMS**

New Technology for the Concrete Jungle

# TITAN

**SMALL, STRONG PRE-CAST MAGNET**

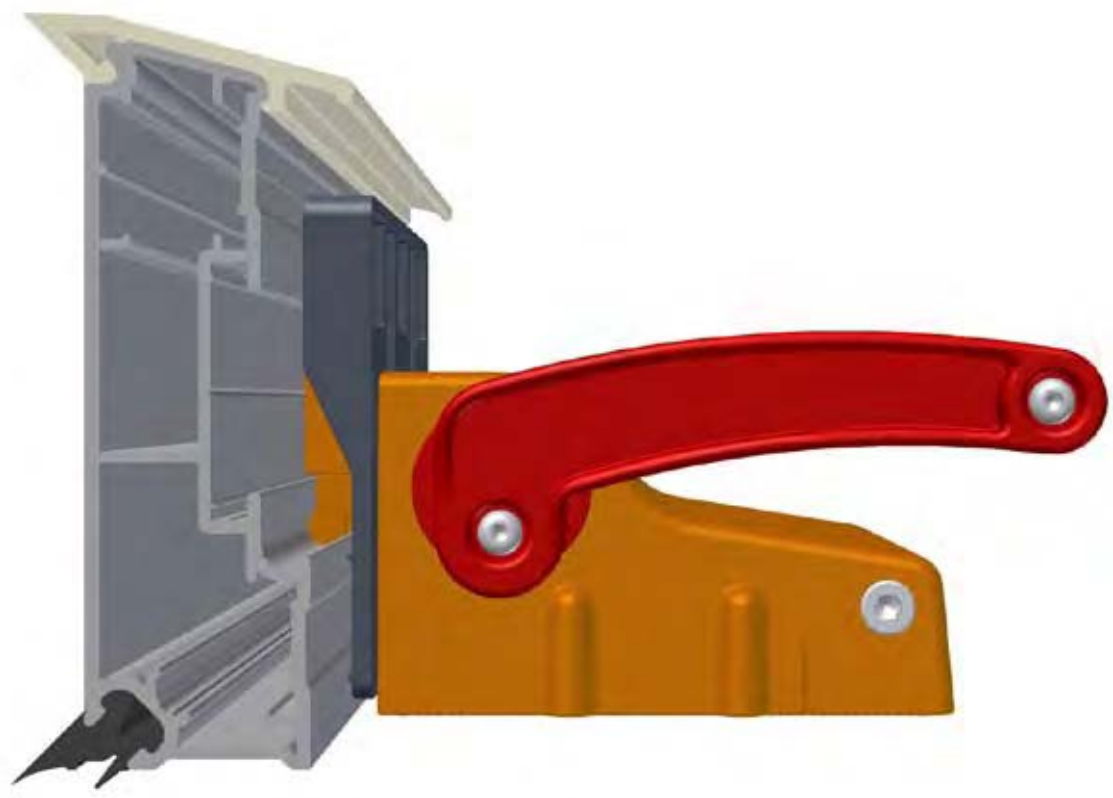



## SRB Titan Precast Magnet Clamps

The new SRB Titan precast magnet clamp will be the world's strongest precast magnet for its size.

The SRB Titan is substantially smaller than other commercially available magnets.

The new Titan has the following novel features:

1. Smaller and Lighter.
2. Substantially Stronger.
3. Protection from Dirt and foreign Metallic/Magnetic matter.
4. Significant Amplification and increased Base Frictional Forces.
5. Absorbs Vibration.
6. Safety – Prevent Injury or Amputation!
7. Safety – The Demagnetising Plate.
8. Eliminate Concrete Sticking.
9. Fulfilling OH&S (Occupational Health & Safety) Obligations.
10. More use of Steel Casting Bed Space.
11. Handles and Safer Handling.
12. Fine Adjustments – Better Panels.
13. Protective Magnet Flap

*Click on the chapter above to hyperlink to the appropriate page.*

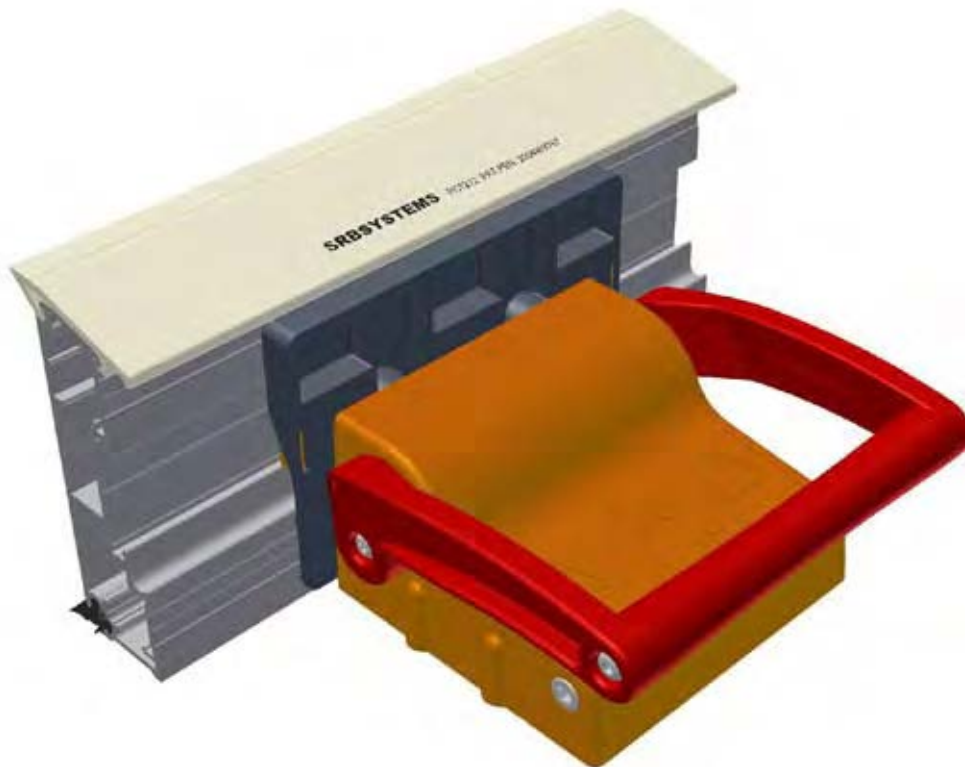



## SRB Titan Benefits

### 1. *Smaller and Lighter*

The SRB Titan is substantially smaller than other comparative any magnet on the market in this pull-down strength category, i.e. over 2200 lbs. magnetic pull-down. The Titan has around 3968 lbs. of pull magnetic pull down force.

Despite its relatively small size, the New Titan Magnet is significantly stronger than other comparative commercially available units.

### 2. *Substantially Stronger*

The SRB Titan is conservatively 10 to 15% stronger than other magnets. Tests on the Titan show that it is stronger in magnetic pull-down force and even more so in Lateral shear force.

The Titan has a much higher shear force to magnetic pull-down force ratio than any magnet currently on the market (i.e. it has more lateral shear force resistance for its magnetic pull down force.) Due to misconceptions and a lack of understanding in the precast industry, magnets are incorrectly classified based on their pull-down force.

The pull-down force is less relevant in relation to supporting a sideform in position during the concrete pour. The most important force is the lateral or horizontal shear force between the magnet and the steel bed, as it is this force that prevents the steel shutters from moving in particular during the concrete vibration process.

Modifying or changing the value of the coefficient of friction in the formula of the magnetic pull-down force can be changed or manipulated to produce misleading results.

To overcome this we at SRB SUBO Pty Ltd (SRB's R&D and Manufacturing Facility) have set up hydraulic testing equipment that accurately tests and plots the shear force resistance of the magnets.

Test results can be submitted on request for the shear force capacity on a smooth steel plate for all currently available commercial magnets, (to replicate an 'actual use' scenario of a pre-cast bed). The graph below illustrates a typical shear test result after hydraulically applying a lateral or horizontal shear load to a magnet after it was engaged.

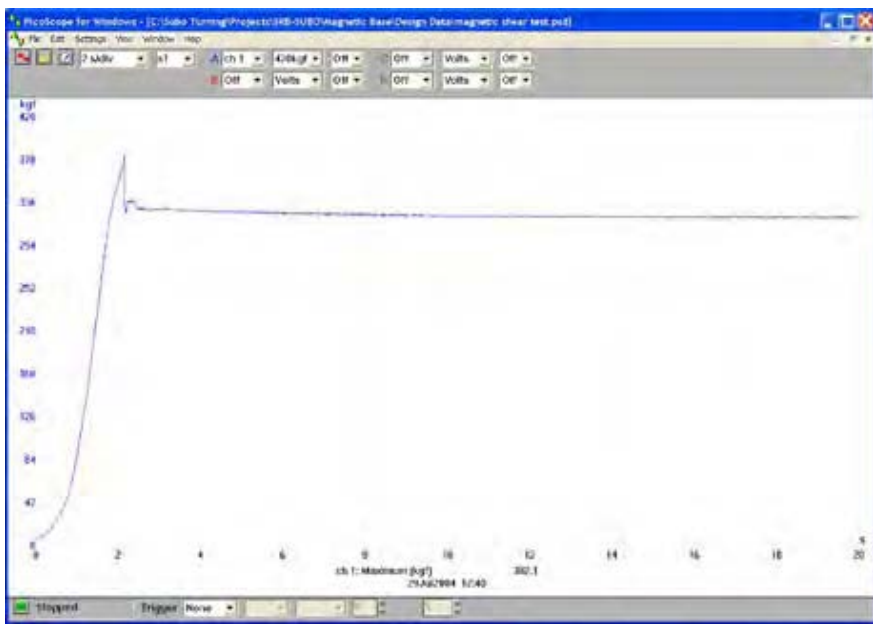



## SRB Titan Benefits

### 3. Fully Sealed Housing

The SRB Titan has a unique rubber base skirt that fully seals the underside of the magnet housing, protecting it from the ingress of dirt, metallic particles and other foreign metallic or magnetic matter.

A major problem with current handle or lever action magnets, is that there is a gap between the magnet housing and the magnetic engagement plate that moves within the housing. This allows for metallic dust, shaving, metal particles, tie wire off-cuts to get caught in the housing and attach to the magnetic plate, as well as for environmental dirt and concrete to get in.

Attaching foreign metal particles to the magnetic base plate creates deformations in the magnetic flux field and weakens the bond of the magnet to the steel bed. The metal particles on the magnet surface and housing rusting can also cause damage to the actual magnetic base plate.

Due to the strength of these magnetic base plates, it is impossible to simply blow, wash out or clean the metal and dust from inside the magnet housing. The only way to do this properly is to disassemble the entire magnet unit to clean it. This is a time consuming and dangerous operation for inexperienced personnel unfamiliar with handling such powerful magnetic packs.

The SRB Titan's entire underside, between the magnetic base plate and the housing, is sealed by a novel and unique rubber skirt. The rubber skirt prevents any foreign matter from getting into the magnet housing or the sides and rear of the magnetic base assembly.

The rubber skirt allows all magnetic materials to be simply brushed off the bottom face of the magnetic base assembly onto the rubber surface, which is not magnetic, without entering the housing. The diagram below clearly illustrates how the magnetic base plate travels through the rubber skirt, thus preventing foreign matter to be caught within, or enter, the magnet housing.

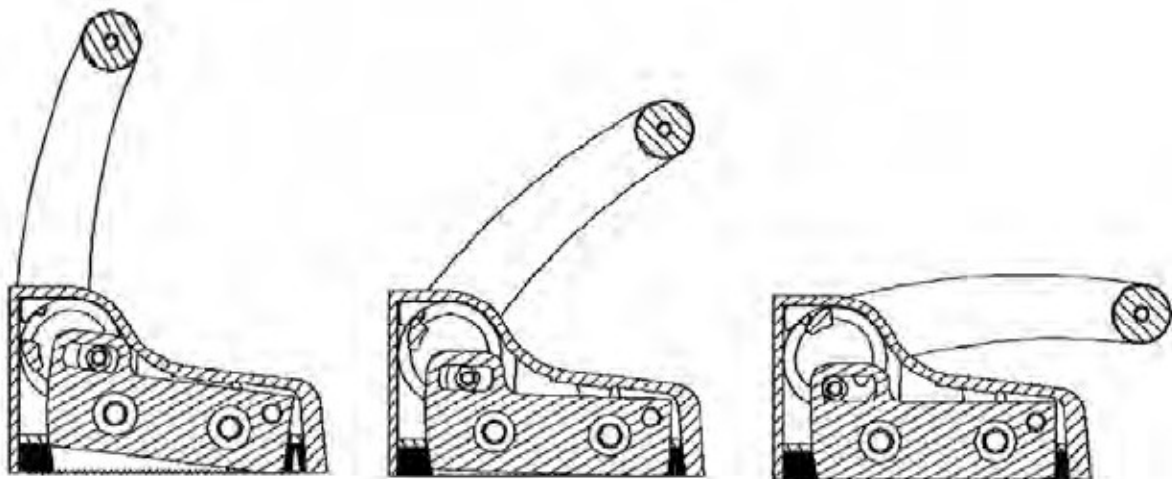



**SRB Titan Benefits**

**4. Amplification and increased Base Frictional Forces**

The rubber skirt to the base of the magnetic housing amplifies and increases base frictional forces. All current magnets on the market are either made from steel, stainless steel or nylon housings. All of these materials have extremely poor frictional forces between them and the polished steel beds – particularly the stainless steel magnets and nylon body magnets.

High frictional forces are desirable as they actually increase the shear or lateral force resistance of the magnet. The rubber skirt protrudes 1 mm below the SRB Titan magnet housing, compressing on contact with the steel bed when the magnet is engaged.

The rubber skirt has a much greater frictional force coefficient with the steel bed than any other material, dramatically improving the shear capacity of the magnet. This feature has been detailed in the SRB Titan magnet patent application.

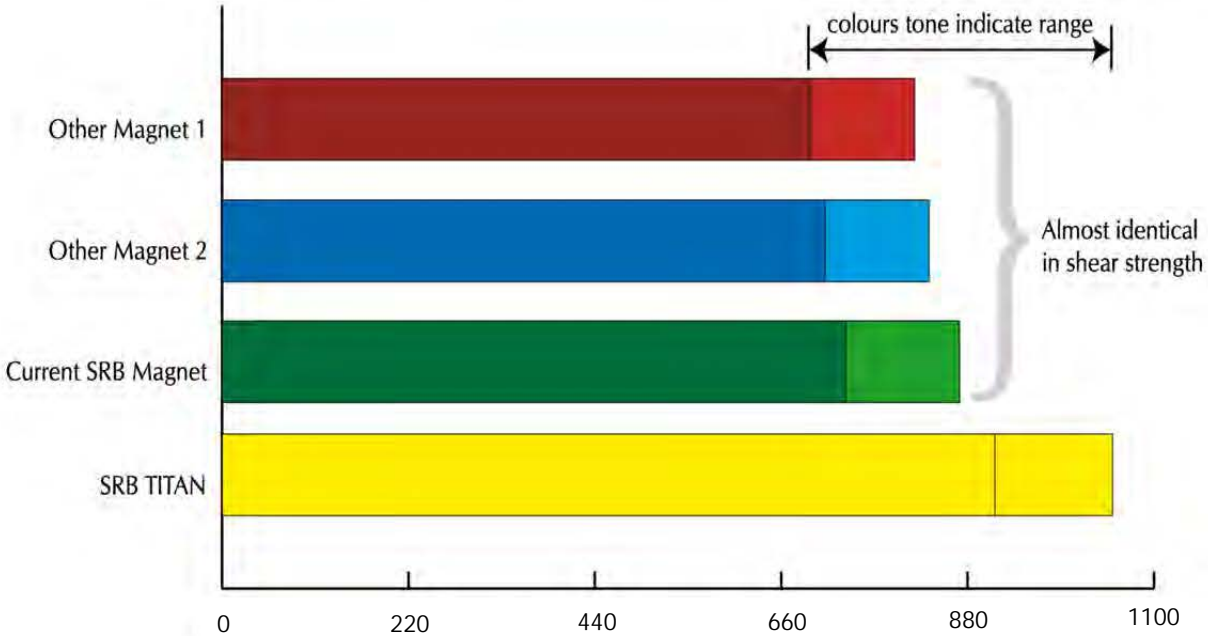

This graph illustrates the difference in shear strength of four magnets; Two common commercially available magnets, the Old SRB Steel Housing Magnet and the SRB Titan. The SRB Titan magnet is 10 to 15% stronger than the other magnets in pull-down force. This is an inappropriate gauge by which to compare a magnet’s strength for its intended use. In our experience, shear force has far more importance in context than pull-down forces.

During our tests, the hydraulic equipment used for the shear test comparison was set up to place a lateral load on the various magnet clamps. The two common commercially available magnets and old steel housing SRB magnets had a shear force load resistance of between 714 lbs. to 836 lbs. The SRB Titan had results that varied between

The graph clearly indicates that the SRB Titan has around 26% greater shear force capacity.



## SRB Titan Benefits

### *5. Absorbs Vibration*

The rubber skirt on the SRB Titan magnet housing absorbs vibration from the pre-cast concrete manufacture process. In static motion most pre-cast magnets are relatively difficult to move laterally. (i.e. when they are placed on a steel bed and the lateral load is applied gradually.)

However, kinetic motion, such as shuddering of poker vibrators, vibrating screed and even vibrating beds can move the magnets laterally. This vibration is an important and necessary process in the pouring of concrete and cannot be reduced or eliminated. Most current magnets are made from steel or stainless steel housings and these vibrations transmit through the magnet bodies causing the magnets to move laterally.

Most of the magnet bodies are made from stainless steel or Nylon and there are almost no frictional forces between these housings and the steel bed to counter any motion caused by lateral impact, vibration or oscillation.

The SRB Titan magnet has a plastic body with a rubber skirt tightly wedged between the body and the magnetic base plate. This rubber skirt acts as a shock absorber between the magnetic base plate and the steel sideform, extensively reducing lateral motion.

### *6. Safety – Prevent Injury or Amputation!*

The rubber base skirt in the SRB Titan prevents any serious damage to an operator's appendages. The SRB Titan magnet has a plastic housing that is 8 mm thick at the rear and 4 mm thick to the sides and front. The rubber skirt totally fills the entire underside of the magnet housing, so no shear zones created by the magnet body. The rubber skirt also extends 1 mm down past the housing, which further prevents the shearing limbs or fingers. The rubber also acts as a dampener and cushion, minimising any injury to any fingers or limbs caught under the magnet.

There are two major safety issues with the handles and levers on current magnets on the market:

- a. The handles or levers create a shear or scissor action with the magnet body or housing;
- b. The handles or levers come into contact with the steel beds creating point of impact at these positions.

The SRB Titan magnetic clamps address these safety issues by totally eliminating any contact between the magnet handles, the magnet housing and the steel beds.





## SRB Titan Benefits

### 6. Safety – Prevent Injury or Amputation (continued)

**Figure 1**



**Figure 1** shows a side profile of the Titan magnet clamp. In this view the magnet clamp is in the fully engaged position. The magnet engagement handles cannot travel down any further towards the steel bed or magnet body. From the side profile it is obvious that there is a substantial amount of clearance between the magnet housing and the magnet handles. This clearance is far greater than the thickness of a finger.

**Figure 2**



**Figure 2** shows a front view or elevation of the Titan magnet clamp. This view illustrates that the magnet handles are narrower on top than on the base thus creating clearance between the magnet housing and the handles with absolutely no contact between the housing and the handles.

**Figure 3**



**Figure 3** shows a plan or top view of the Titan magnet clamp. From this view it is clearly illustrated that there is substantial clearance between the magnet handles, the magnet handle bar and the magnet housing. The design totally eliminates the possibility of fingers, hands or other limbs, as well as objects being caught between the handles and the magnet housing.

**Figure 4**

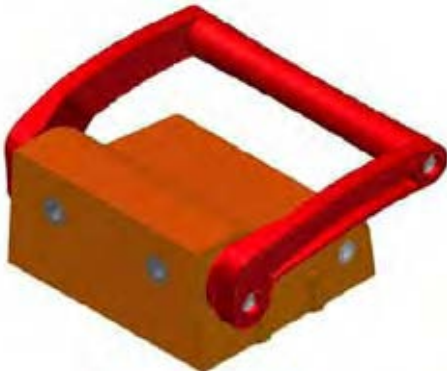

**Figure 4** shows a 3D view of the SRB Titan magnet clamp in the fully engaged position, showing both the vertical and horizontal clearance and magnet body design.



## SRB Titan Benefits

### *7. Safety – The Demagnetising Plate*

The SRB Titan has a demagnetising plate that keeps the magnetic base assembly secured in the disengaged position preventing the magnetic base plate self-engaging to the steel bed. The demagnetising plate secures the magnetic base plate against the top of the magnet body when disengaged, keeping it safe and preventing the magnetic base from pulling against the steel table unexpectedly.

This function is extremely important for safety and in the practical operation of the magnetic clamp.

The magnetic base plate could easily move from its disengaged to its engaged position if there was no mechanism for supporting the magnetic base plate in its disengaged position. Even if there is nothing between the magnet clamp and the steel bed, the sudden magnetic force of the clamp's attraction to the steel bed could cause injury to the operator.

The new Titan has a plastic body and steel inserts have been placed in the top of the housing to keep the magnetic base assembly locked in the disengaged position through its magnetic bond to these steel inserts.

The SRB demagnetising plate supports the magnetic base plate in the disengaged position until it is required to engage the magnetic base plate to the steel table.

### *Demagnetising Aspect*

Another very important feature of the demagnetising plate is that magnetism reduces on the bottom face of the magnetic base assembly. Without a steel or magnetic surface to be attracted to, the magnetic forces to the top and bottom of the assembly are the same. However, when the magnetic base assembly engages to a steel bed, the magnetic force on the top of the assembly (that is not engaged) reduces.

This means that the magnetic force on the top of the magnetic base assembly is weaker when it is engaged on its bottom face to a steel bed. The same characteristics apply in reverse when the magnetic base assembly is engaged to the demagnetising plate in the magnet housing.

The weakened magnetic field on the bottom face of the magnetic base assembly is extremely beneficial because there is less chance that any metallic or magnetic objects will bond to the magnetic base assembly and, if they do, it would be a much weaker bond and easier to remove.

This feature is novel and has been included as a novel feature in the SRB patent application for the Titan magnet.





## SRB Titan Benefits

### *8. Eliminate Concrete Sticking*

A major problem in the concrete industry is that concrete will stick to almost anything. Concrete is highly alkaline and as a result etches the surface of most materials it comes into contact with and bonds to those surfaces. This is generally true for all metals including aluminium, steel and stainless steel.

There is a misconception that concrete will not stick to stainless steel. In fact, after a short period of use, the alkalinity in the concrete will etch the stainless steel surface as well and stick to it. This is evident from all the prior stainless steel model magnets.

SRB Titan magnet housing and handles are made from strong glass reinforced plastic. Plastic is one of the materials that concrete does not stick to. The Alkalinity in the concrete does not affect the surface of the plastic.

As concrete does not stick to plastic there will be substantially less cleaning and maintenance required on the SRB Titan magnets – this is further enhanced by the SRB magnets being fully sealed even from the underside by the solid rubber skirt.

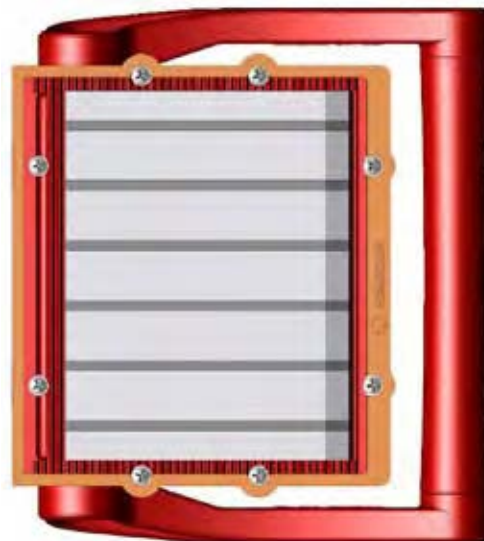



### SRB Titan Benefits

#### 9. Fulfilling OH&S (Occupational Health & Safety) Obligations

The SRB Titan is the lightest, not only smallest, magnet for its magnetic pull-down strength class. The SRB Titan magnet *only* weighs 9.8 pounds compared to 15.4 lbs.-16.5 lbs for most equivalent commercially available magnets.

To pour an average panel would take around 20 magnets to be carried to casting position and attached to the sideforms. After the curing process these magnets are removed from the sideforms and carried back to their storage position.

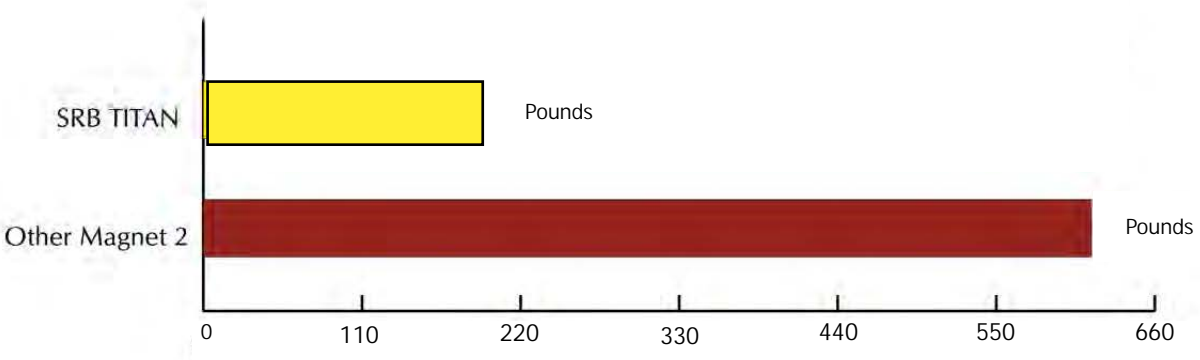
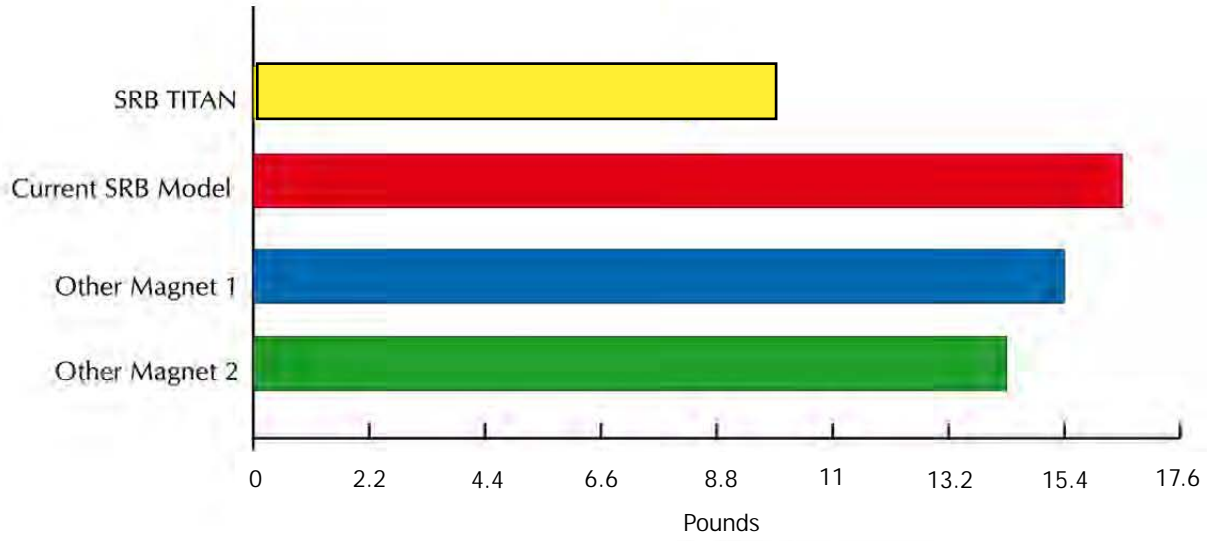

Based on 20 magnets required for the completed casting of 1 panel:  
**Other Magnets:** A total of 617 lbs. of magnets needed to box and strip one single panel.  
**SRB TITAN:** A total 196 lbs. of magnets needed to box and strip one single panel.



## SRB Titan Benefits

### *9. Fulfilling OH&S (Occupational Health & Safety) Obligations (continued)*

The weight of the SRB Titan magnet is around 46% less than the other magnets and is therefore far less strenuous on operators. This should translate into greater performance and productivity.

One team of two men is generally required to box up (place sideforms and fixings) 12 panels each day. This means that 2 men are expected to carry 20 magnets to each panel. So, for 12 panels in the course of the day, this equates to 240 magnets to be carried to box the 12 panels and then, 240 magnets to be carried again when the panels are stripped.

Other Magnets weighing in around 15.4 lbs. each, so the two operators need to carry  $240 \times 15.4 \text{ lbs.} = 3,696 \text{ lbs.} \times 2 = 7,392 \text{ lbs.}$  (3.696 tons) in magnets alone – just to box and strip the panels in *one* day. If the task is split evenly between the two men, then each man carries a staggering weight of 1.848 tons per day!

Note: *boxing is only done for half the day; operators are required to perform other duties during the course of the day.*

SRB Titan magnets only weigh 9.8 lbs. each. Therefore, to box 12 panels a day, the total weight carried is 2.35 tons per day. This is equivalent to 1.176 ton per man, per day. Compared to the heavier magnets, this is a significant reduction where each man would be required to carry a staggering 1.848 tons per day!

Lower back strain accounts for a significant number of OH&S claims as well as loss in productivity. The process of placing of magnets compromises an operator's ability to squat in the posture of best lifting and lowering principles. Generally, the operators simply bend over, exerting an immense load on their lower back.





## SRB Titan Benefits

### *10. More use of Steel Casting Bed Space*

The SRB Titan magnet is only 5.1" deep x 5.9" wide x 3" high. The SRB Titan magnet is the smallest magnet for its strength allowing more use of the steel casting bed space.

The depth of the magnet is the most important measurement for the precast application as it is this dimension that uses up the valuable steel bed space. The SRB Titan was specifically designed with this in mind.

The SRB Titan magnet body can hang off the table end by 1 inch and still have the entire magnetic base assembly engaged. Therefore, the size and design of the SRB Titan allows the casting of wider panels and dramatically improves the cost efficiency and productivity of the yard.

The SRB Titan has small markings on the sides of the magnet showing the position of the rear of the magnetic base plate. This ensures that the operator can hang the magnets off the bed up to those marks and still have the entire base plate fully engaged on the bed.

### *11. Handles and Safer Handling*

All the current magnets on the market either have a 'push button' operation for engagement and disengagement or a pin fixed lever that is used to pry the magnet from the steel casting table by lifting a magnet edge or side.

Both these methods are extremely cumbersome and very out-dated. To disengage the push button type magnets the operators need to carry around with them long steel levers and literally pry the magnet pack of the steel table by levering the button attached to the magnetic pack at the base off the magnet housing.

This is slow, cumbersome and requires a lot of work and energy by the operator with the added disadvantage of causing damage to the magnet housing over time through the levering process particularly with housings made from materials like aluminium.

There is a lot of lost time in productivity in the operators having to look for and carry the long bars / levers which also get lost requiring replacement etc.

These types of magnets also do not lend themselves to be very easily carried, handled, placed & installed and generally an operator can only safely carry one magnet at a time.

The SRB Titan magnet is the only magnet on the market with a 'patented' handle operation that totally eliminates the need or requirement for long levers or bars to be used in the operation.

The magnets are very easily handled by the operator and in fact the operator can carry 4 magnets at a time two in each hand turned back to back simply by the handles.

For all the other magnets the operators literally need to handle and carry those magnets by their bodies or housings which not only makes it difficult to carry but also very cumbersome and hard to install or place accurately in position. There is also the added safety issue of having to handle the magnets in such a way i.e. by carrying and placing them by holding onto the body or housing, that the magnets can be very easily dropped.

The handles also allow for very simple and easy placement of the magnets into position as well as removal or disengagement on completion of the process – no need to look for and carry long levers and bars.



## SRB Titan Benefits

### *Special Safety Features of the SRB Titan Magnet Clamp*

- The SRB Titan magnet is designed to limit and restrict the motion of the engagement handles within the actual internal mechanism.
- The SRB Titan magnet does not rely on the handle motion being stopped or limited via contact with the steel bed or magnet body.
- The SRB Titan magnet design does not allow the handles to dangerously over-rotate. The movement of the handles limited by the actual cam-shaft that lifts and lowers the magnetic base assembly. It is physically impossible to over-rotate the handles in any motion forward or backwards.

### *12. Fine Adjustments – Better Panels*

Current magnets on the market are operated by a simple lever, which lifts the magnet edge to break the magnetic bond with the table.

This tilts the entire magnetic block at an angle. Therefore, the clamp cannot be attached to the sideforms while an operator is engaging the magnet clamp lever. Should an operator need to adjust the sideform, the clamp needs to be totally disengaged from the sideform, adjusted and then re-attached to the sideform – a really slow and cumbersome process.

It is extremely difficult to accurately place the clamp because it is tilted when lowered to the bed. When the magnetic block gets close to the bed, the immense magnetic force suddenly attracts to the steel. Generally, an operator cannot hold the clamp a short distance away from the steel bed to accurately align its position – it is an 'accepted' process of trial and error.

If the operator is capable of supporting the magnet clamp at a close distance, then it is likely that the magnetic force of that clamp is not really sufficient to support the formwork in position.

Magnets may need some minor positioning adjustments when engaged. A typical scenario is to take out any minor bends or bows in the sideforms. The sideforms can have slight bows. Magnets are used to straighten these little bows out or to correct the sideforms position.

If the magnets are attached to the sideform but not engaged when the operator moves the sideform, the magnets move as well, which is not always desirable. Minor adjustments to engaged magnets mean that the operator must somehow try and hold an 8 kg magnet and push the sideform either with his other hand or feet and then re-engage the magnet when the sideform is in correct position.

In practice, if a sideform has a slight bow, operators moved the magnets by hitting them with hammers. As stated earlier, magnetic forces do not hold well against kinetic motion or impact due to poor friction between the underside of the magnets and the steel beds. Older model SRB magnets were made from steel and were robust enough to take impact hits from a hammer, however this is a major problem with other magnets.

The new SRB Titan is also designed to sustain blows to the rear of the magnet housing. The rear wall is 8 mm glass reinforced plastic with a specially designed rubber skirt to cushion any blows.



## SRB Titan Benefits

### 12. Fine Adjustments – Better Panels (continued)

#### SRB Titan Two Stage Engagement

The SRB Titan magnetic base assembly has a two-stage engagement; initially only semi-engaging to allow fine adjustments and the second notch for full engagement once the handle is completely lowered. This novel feature enables the magnet base assembly to be supported at a close distance to the steel bed, yet not fully engaging to the steel bed, allowing the sideform and clamp to be positioned properly before full engagement.

Due to the extremely large magnetic force this type of adjustment cannot be controlled by human operators, so SRB have devised a methodology for this process to be controlled mechanically within the magnet clamp itself.

When the magnet handles are pushed down to engage, they lock at the first stage exerting only a portion of the magnetic force on the steel bed.

In this partial state of engagement, the frictional forces inbuilt on the magnet are negligible. So, the magnet will exert sufficient enough magnetic force on the table to support the sideforms in position and still enable finer adjustments to be made by light taps to the magnet's body.

The rear of the Titan magnet is 8 mm thick with a solid rubber internal skirt that is specifically designed to absorb these impact blows. In fact, the SRB Titan is designed to tolerate blows from all other directions as well.

**Special Note:** The housing is made from glass reinforced plastic with a rubber skirting, which significantly minimises workplace noise levels involved in managing the magnet in a precast environment.

Once the magnet is in its final position, the magnet can be full engaged by simply pushing down the handles.

#### SRB Titan Magnet Engagement

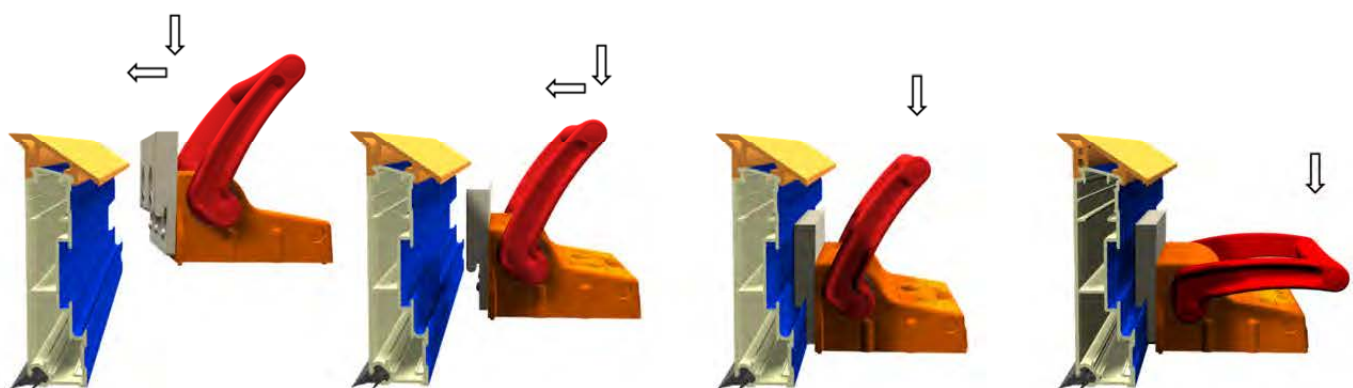

The Connection and engagement of the SRB Titan Magnet to Spartan Sideform is extremely quick and simple not involving or requiring any bolts, screws or tools.

The Titan Magnet with appropriate size adaptor for sideform affixed is lowered against the rear of the sideform. The Ball Lock in the face of the adaptor is placed into the ball lock rail strip at the rear of the Sideform and magnet clamp released onto the casting bed with ball lock in the adaptor engaged in the ball lock rail strip on the sideform.

The magnet handles are then lowered towards the steel casting Table / Bed to engage the magnet to the steel base.



## SRB Titan Benefits

### *SRB Titan Magnet Disengagement*

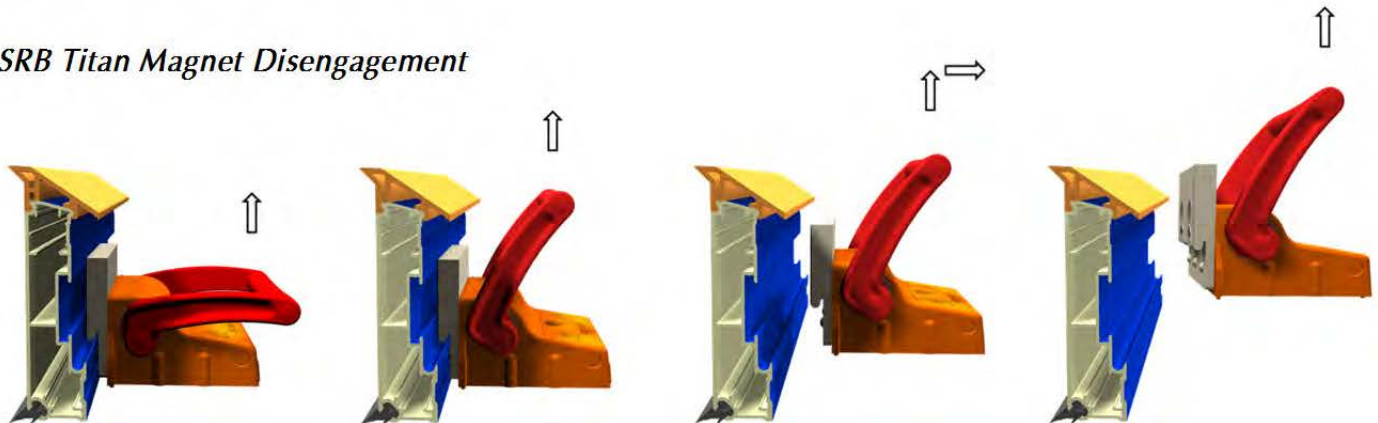

The Titan Magnet is disengaged from the sideform after concrete has set in the mould simply by lifting up on the magnet handle.

Once disengaged, continue with the upward motion holding onto the handle, lifting the magnet upwards. The adaptor attached to the magnet will come out of the ball lock rail in the rear of the sideform disengaging the magnet completely from the sideform.

Quick and easy engagement and disengagement, No need for levers or bars, screws, bolts and spanners - It cannot be any more simple than this.

### *SRB Titan Magnet Semi-Engagement Function for Fine Adjustment*

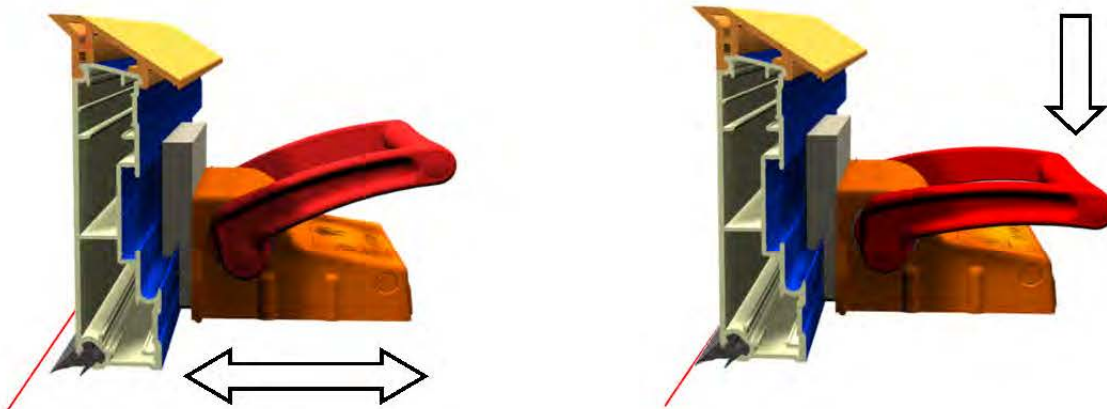

The Titan Magnet allows for semi engagement of the magnetic load by rotating the handle partially towards the steel table i.e. rotate the handles by only 1/2 rotation which only provides partial magnetic load of the magnet pack and not the full magnetic loading or pull down force.

This then does not engage the full magnetic load of the magnets to the table thus enabling the magnet to be tapped by foot for fine adjustment to be made to the sideform position. No need to hit magnets or sideforms with hammers for fine adjustment.

Once the shutters / Sideforms are in the correct location the magnets handles are simply pushed down fully thus providing the full magnetic load of the magnet pack to the steel table.



## SRB Titan Benefits

### 13. Protective Magnet Flap

The SRB Titan magnet has a unique and novel combination Rubber & Plastic Magnet flap that is secured to the magnet housing and clips to the Magnet handles. The flap is ergonomically designed to fit around the operator's hand holding the magnet clamp handle and follows the handle operation through its clip to the handles so as not to get in the way.

The magnet Flap provides protection to the magnet clamp from concrete spillage during the concrete pour so as to minimise cleaning and maintenance to the magnet clamp resultant from concrete spillage.

The rubber is a chemically resistant Nitrile rubber so as to counter the harsh abrasiveness of Release Agents and Oils that are used on the steel casting tables in the precast application. The handle is designed to be very simply and easily replaced if damaged

